

Welcome to our school.



Everyone at Hursthead Junior School demonstrates our REAL wheel values every day. We are all determined to be **RESPONSIBLE ENTHUSIASTIC ASPIRATIONAL LEADERS** in our work, our play and our interactions with each other. Look out for our Star Award badge winners and Role Models who consistently show these values in school.

Our School is a Gold Rights Respecting School

All of our children and staff follow the United Nations Convention of the Rights of the Child.

The Articles are referenced in our policies and procedures, our curriculum and our assemblies.

See if you can spot what the Right of the Month is as you move around school.



How many times will you see someone modelling our learning super powers during your visit?

adaptability

kindness, empathy and gratitude

determination

self-control

independence

communication



Year 4

Year Group Meeting For Parents
Miss Clarke, Miss Parker, Mr Drew

Staff in Class

The year 4 classes will be covered by different teachers on certain days:

Thursday:

Miss Walker/Ms Taylor/Miss Potter

TAs shared across Year 4 Mrs Hall, Mrs Murray and Mrs Findlay



Learning superpowers

- ADAPTABILITY
- EMPATHY, GRATITUDE AND KINDNESS
- DETERMINATION
- SELF-CONTROL
- INDEPENDENCE
- COMMUNICATION



We are all learners.
We achieve together through
our own endeavours.
Be empowered to
become
independent.

We embrace life.
Take every opportunity to be part
of the team and have fun.
We celebrate getting
the most out of what
we put in to our
learning.

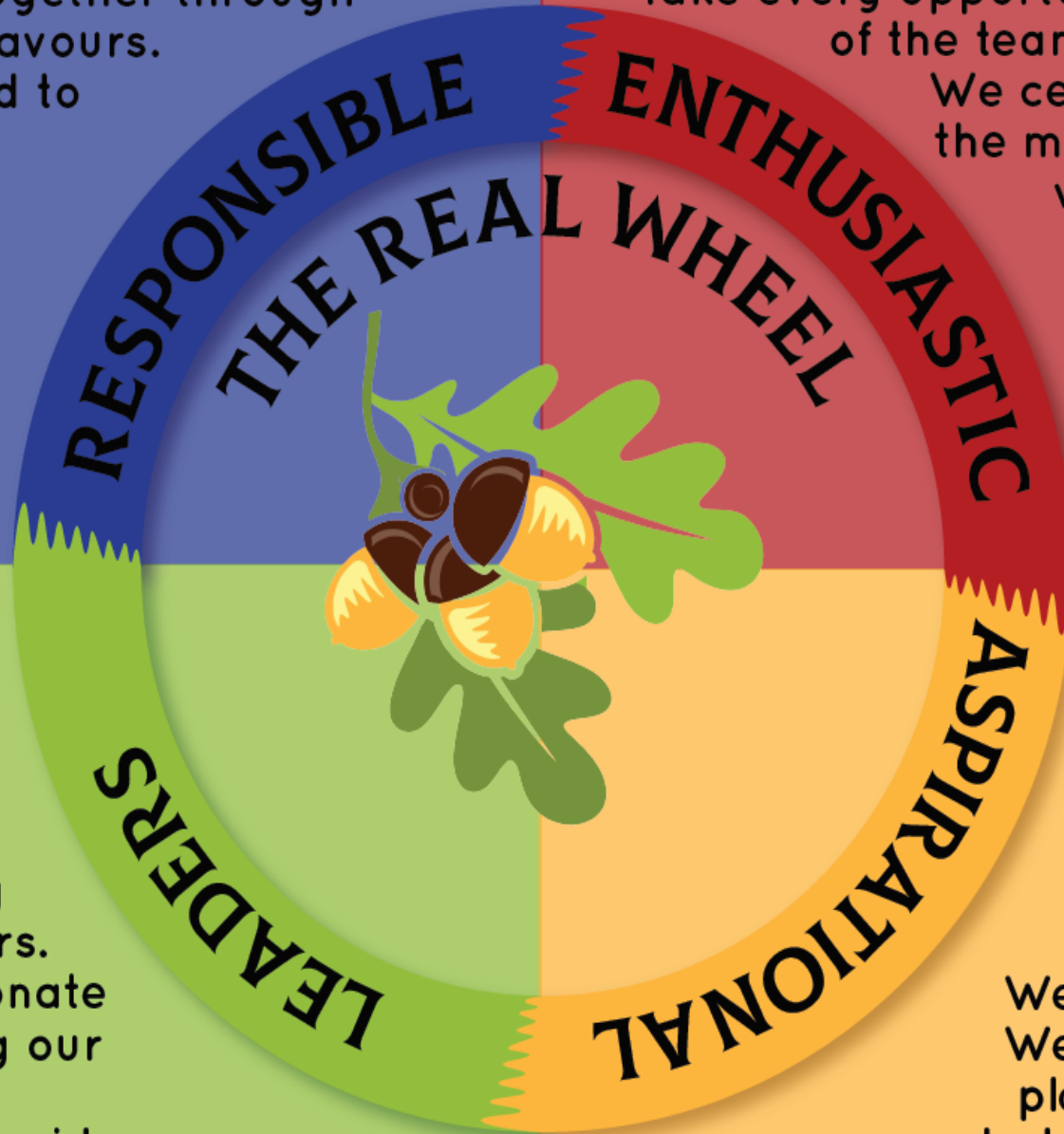

We are strong
communicators.
We are passionate
about shaping our
community.
Be open to new ideas.
Make a difference!

We are ambitious.
We persevere and
place no limits on
what we accomplish.
Rise to the challenge!

UNCRC

Universal

Rights are for all children.

Inherent

Rights are from birth.

Inalienable

Rights cannot be taken away.

Unconditional

Rights do not have to be earned.

Indivisible

Rights are equally important.

1 DEFINITION OF A CHILD
2 NO DISCRIMINATION
3 BEST INTERESTS OF THE CHILD
4 MAKING RIGHTS REAL
5 FAMILY GUIDANCE AS CHILDREN DEVELOP
6 LIFE, SURVIVAL AND DEVELOPMENT
7 NAME AND NATIONALITY
8 IDENTITY
9 KEEPING FAMILIES TOGETHER
10 CONTACT WITH PARENTS ACROSS COUNTRIES
11 PROTECTION FROM KIDNAPPING
12 RESPECT FOR CHILDREN'S VIEWS
13 SHARING THOUGHTS FREELY
14 FREEDOM OF THOUGHT AND RELIGION
15 SETTING UP OR JOINING GROUPS
16 PROTECTION OF PRIVACY
17 ACCESS TO INFORMATION
18 RESPONSIBILITY OF PARENTS
19 PROTECTION FROM VIOLENCE
20 CHILDREN WITHOUT FAMILIES
21 CHILDREN WHO ARE ADOPTED
22 REFUGEE CHILDREN
23 CHILDREN WITH DISABILITIES
24 HEALTH, WATER, FOOD, ENVIRONMENT
25 REVIEW OF A CHILD'S PLACEMENT
26 SOCIAL AND ECONOMIC HELP
27 FOOD, CLOTHING, A SAFE HOME
28 ACCESS TO EDUCATION
29 AIMS OF EDUCATION
30 MINORITY CULTURE, LANGUAGE AND RELIGION
31 REST, PLAY, CULTURE, ARTS
32 PROTECTION FROM HARMFUL WORK
33 PROTECTION FROM HARMFUL DRUGS
34 PROTECTION FROM SEXUAL ABUSE
35 PREVENTION OF SALE AND TRAFFICKING
36 PROTECTION FROM EXPLOITATION
37 CHILDREN IN DETENTION
38 PROTECTION IN WAR
39 RECOVERY AND REINTEGRATION
40 CHILDREN WHO BREAK THE LAW
41 BEST LAW FOR CHILDREN APPLIES
42 EVERYONE MUST KNOW CHILDREN'S RIGHTS

43-54
HOW THE CONVENTION WORKS

CONVENTION ON THE RIGHTS OF THE CHILD

Behaviour

Focus

Engage

Learn



✓ **Silent**

✓ **Sensible**

✓ **Single File**

✓ **Sense of Pride**





Dojo points are awarded every day when we show positive learning behavior- “Focus, Engage, Learn”.



Silver Superstar sticker is awarded to the person in our class with the most dojo points each week.



Star Award certificate is awarded once a week for a great piece of work, demonstrating REAL wheel values or using our learning superpowers.



A praise postcard can be awarded to anyone in school in recognition of a positive choice they make.



A Rights Respecting card is awarded when we do something that positively demonstrates upholding children’s rights. The cards are added up each week and count towards the Family Trophy which is awarded at the end of each term.

Special Rewards



Headteacher award
for exceptional work, behaviour, attitude or effort.



Star Award Badges
once per term per family per year group for demonstrating our REAL wheel values and learning super



Role Model Badge
in Year 6 for those children who exemplify our Hursthead ethos and values consistently.

What happens if we make a poor choice?

CHOICE

 We will be reminded to make positive choices that respect children's rights, demonstrate the REAL wheel values and use our learning superpowers.



CHANCE

 If we do not start to make better choices, we will be given a verbal warning that we need to change our behaviour immediately. We will be reminded again of the behaviour that is expected.



CONSEQUENCE

If we have not changed our behaviour, then we will miss ten minutes of our next lunchtime and stay inside the classroom with a teacher to discuss our actions and choices.



If we are in the playground, we will miss ten minutes of playing and instead stay with a teaching assistant to discuss our actions.

What happens if we continue to make poor choices?

We will be sent to the one of the Assistant Heads and our class teacher will speak to our parents or carers about our behaviour choices.



We might be put onto a "Report Card" where will have to report after every lesson to one of the Assistant Heads to demonstrate that we are making an effort to improve our behaviour.

English

Inspired by Firebird – Can I explore how characters are used to create suspense?

Inspired by the Brazilian favelas – Can I write a letter to persuade the reader?

Inspired by Scott's expedition to the Antarctic – Can I write information that will entertain Year 3 children?

Inspired by Antarctica – Can I write an interesting newspaper report?

We have a strong focus on the edit and revise process:

Edit = correcting spellings, punctuation etc.

Revise = Improving the writing itself e.g. improving word choice.

Inspired by Gorilla - Can I develop characters in order to connect with a reader?

Inspired by inventors – Can I write a biography?

Inspired by Charlie and the Chocolate Factory – Can I explore how a character provokes a response?

Inspired by Charlie and the Chocolate Factory -Can I create an imaginary world that comes alive to the audience?

Inspired by the Romans – Can I investigate how to develop historical settings in stories?

Inspired by famous speeches – Can I persuade an audience?

Inspired by poetry – Can I create a poem with rhythm and rhyme?

Inspired by debate – Can I write a balanced argument?



Maths

Place value

Addition and subtraction

Area

Multiplication and division

Multiplication and division

Length and perimeter

Fractions

Decimals

Decimals

Money

Time

Shape



Statistics

Position and direction

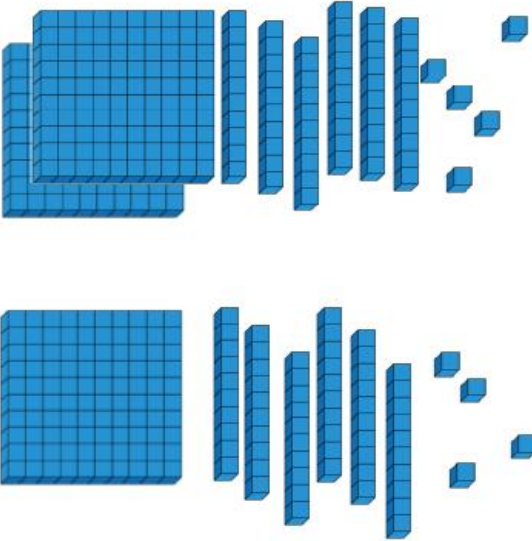

Maths

Add numbers with up to 3 digits

| Concrete | Pictorial | Abstract | | | | | | | | | | | | | | | | | | | | | | | | |
|---|--|----------|------|------|----|--------|------|---|--------|------|---|--|--|----------|------|------|-----|--|-------|---|--|-------|---|--|--|---|
|  | <table border="1" data-bbox="710 378 1246 621"> <thead> <tr> <th>Hundreds</th> <th>Tens</th> <th>Ones</th> </tr> </thead> <tbody> <tr> <td>●●</td> <td>●●●●●●</td> <td>●●●●</td> </tr> <tr> <td>●</td> <td>●●●●●●</td> <td>●●●●</td> </tr> <tr> <td>●</td> <td></td> <td></td> </tr> </tbody> </table> <p data-bbox="724 628 879 664">●</p> <table border="1" data-bbox="710 763 1246 1006"> <thead> <tr> <th>Hundreds</th> <th>Tens</th> <th>Ones</th> </tr> </thead> <tbody> <tr> <td>■ ■</td> <td> </td> <td>.....</td> </tr> <tr> <td>■</td> <td> </td> <td>.....</td> </tr> <tr> <td>■</td> <td></td> <td></td> </tr> </tbody> </table> <p data-bbox="753 1006 917 1049">■</p> | Hundreds | Tens | Ones | ●● | ●●●●●● | ●●●● | ● | ●●●●●● | ●●●● | ● | | | Hundreds | Tens | Ones | ■ ■ | | | ■ | | | ■ | | | <p>Partitioning <i>Partition into hundreds, tens and ones before regrouping.</i></p> <p>265 + 164 $200 + 100 = 300$ $60 + 60 = 120$ $5 + 4 = 9$ $300 + 120 + 9 = 429$</p> <p>Expanded column written method <i>See above for exemplification and calculation steps.</i></p> <p>Compact column written method <i>See above for exemplification and calculation steps.</i></p> |
| Hundreds | Tens | Ones | | | | | | | | | | | | | | | | | | | | | | | | |
| ●● | ●●●●●● | ●●●● | | | | | | | | | | | | | | | | | | | | | | | | |
| ● | ●●●●●● | ●●●● | | | | | | | | | | | | | | | | | | | | | | | | |
| ● | | | | | | | | | | | | | | | | | | | | | | | | | | |
| Hundreds | Tens | Ones | | | | | | | | | | | | | | | | | | | | | | | | |
| ■ ■ | | | | | | | | | | | | | | | | | | | | | | | | | | |
| ■ | | | | | | | | | | | | | | | | | | | | | | | | | | |
| ■ | | | | | | | | | | | | | | | | | | | | | | | | | | |
|  | <p>How to add three digit numbers together with exchanges.</p> | | | | | | | | | | | | | | | | | | | | | | | | | |

PSHE

Families and Friendships
Belonging to a community
Respecting Ourselves and Others including protected characteristics: age, marriage and civil partnership, pregnancy and maternity

Media literacy and digital resilience
Safe relationships
Respecting Ourselves and Others including protected characteristics: disability, race, religion or belief

Keeping Safe
Growing and changing
Respecting Ourselves and Others including protected characteristics: sex, sexual orientation and gender reassignment

PSHE spiral curriculum

Termly themes and circle time.

Mental Health Champions

Ongoing throughout the year: Financial Education plus Physical Health and mental wellbeing

Creative Curriculum Overview

| CREATIVE CURRICULUM | NEXT STOP SOUTH AMERICA! A dream destination? | THE ROMANS What have the Romans done for us? | A LIGHTBULB MOMENT! What qualities does a good inventor need? |
|---------------------|---|--|--|
| | <p>LAUNCH PAD – Brazilian Carnival – Dress up Science - Habitats Humanities – Brazil – human and physical features, contrasting locality, climate (rainfall) Art – Frida Kahlo- Drawing LANDING PAD – Google Voyager Enrichment activity – conducting surveys in the local community.</p> | <p>LAUNCH PAD – Dress up day Science – Forces – Friction, air and water resistance Using a force meter Humanities- settlements, map of Britain, land use and patterns changed over time Map of the Roman empire over Europe Contrasting localities. Art – Clay Roman vases LANDING PAD – Castleton residential Enrichment activity – Castleton</p> | <p>LAUNCH PAD – Redesign a backpack Science – Electricity (circuits, conductors and insulators) Humanities – History of important inventions and inventors Art and D&T – <u>Electrical Systems</u> - (simple circuits) Steady Hand Game LANDING PAD – Design a life without electricity/ Virtual museum exhibition Enrichment activity - Transport museum visit/ MOSI TBC</p> |
| | <p>FROZEN PLANET Why do people risk their lives to explore different parts of the world?</p> | <p>THE ANGLO-SAXONS Better together or better apart?</p> | <p>CHOCOLATE! Is the price of chocolate too high?</p> |
| | <p>LAUNCH PAD – Explorer visit- Misba Khan – dress up arctic explorers Science – Solids and liquids Measuring temperature Humanities – Polar regions and climate History of Polar exploration – Cpt Scot Art and D&T – Art media (painting to create effects (Northern Lights) Food (Using the hob / chopping (bridge & claw hold) Explorer’s Stew LANDING PAD – Outdoor Orienteering Enrichment activity – Misba Khan</p> | <p>LAUNCH PAD – Anglo-Saxon day- Anglo Saxon Visitor – making amulets Science – Human skeleton (bones, muscles and growth) Teeth Humanities – Invaders and Settlers Locate Viking and Roman settlements Art and D&T – Matisse collage Structures- (Sawing wood to make the frame) Anglo Saxon Houses LANDING PAD – Would you rather be a Roman or Anglo-Saxon? Debate Enrichment activity – Anglo Saxon Visitor</p> | <p>LAUNCH PAD – Chocolate lollipops Science – evaporation and condensation Humanities – World map skills including climates The history of chocolate Fair Trade including children’s rights Art and D&T – Relief printing inspired by tree rings. Design and make chocolate lollipops Design packaging for a chocolate bar LANDING PAD – Design a new chocolate bar wrapper Enrichment activity- Whitworth Art Gallery</p> |

Homework



30 minutes each week



A spelling activity will be sent home each week. Once completed, we will encourage the children to spend some time practising their spellings in their spelling log as well.



For most of our children reading chapter books, teachers will be checking that they are reading between 60 -100 pages (minimum) a week.

TT Rockstars

- Children's usernames and passwords are in reading diaries.
- Achievements are recognised by Mrs Kendrick and are displayed on the maths wall in school
- Great way to consolidate number fluency – essential skills that underpin Y4 curriculum.
- Times tables practice essential – Year 4 online test





Effort

Fluency

Gig

Studio

Soundcheck

STATS BOLT-ON

Today

Yesterday

7 days

14 days

30 days

All Time

Custom

STATS BOLT-ON

% Active

100 %

Over the last 7 days

+ 97 %

On previous 7 days

Avg Daily Mins

1 MINS

Over the last 7 days

+ 0 mins

On previous 7 days

 Graph

Avg Coins Earned

493

Over the last 7 days

- 343

On previous 7 days

Avg Correct Answers

59

Over the last 7 days

- 48

On previous 7 days

 Graph

Heatmap

| | 10 | 2 | 5 | 3 | 4 | 8 | 6 | 7 | 9 | 11 | 12 |
|----|-------|------|------|------|------|-------|------|------|------|-------|-------|
| 10 | 10×10 | 10×2 | 10×5 | 10×3 | 10×4 | 10×8 | 10×6 | 10×7 | 10×9 | 10×11 | 10×12 |
| 2 | 2×10 | 2×2 | 2×5 | 2×3 | 2×4 | 2×8 | 2×6 | 2×7 | 2×9 | 2×11 | 2×12 |
| 5 | 5×10 | 5×2 | 5×5 | 5×3 | 5×4 | 5×8 | 5×6 | 5×7 | 5×9 | 5×11 | 5×12 |
| 3 | 3×10 | 3×2 | 3×5 | 3×3 | 3×4 | 3×8 | 3×6 | 3×7 | 3×9 | 3×11 | 3×12 |
| 4 | 4×10 | 4×2 | 4×5 | 4×3 | 4×4 | 3.88s | 4×6 | 4×7 | 4×9 | 4×11 | 4×12 |
| 8 | 8×10 | 8×2 | 8×5 | 8×3 | 8×4 | 8×8 | 8×6 | 8×7 | 8×9 | 8×11 | 8×12 |
| 6 | 6×10 | 6×2 | 6×5 | 6×3 | 6×4 | 6×8 | 6×6 | 6×7 | 6×9 | 6×11 | 6×12 |
| 7 | 7×10 | 7×2 | 7×5 | 7×3 | 7×4 | 7×8 | 7×6 | 7×7 | 7×9 | 7×11 | 7×12 |
| 9 | 9×10 | 9×2 | 9×5 | 9×3 | 9×4 | 9×8 | 9×6 | 9×7 | 9×9 | 9×11 | 9×12 |
| 11 | 11×10 | 11×2 | 11×5 | 11×3 | 11×4 | 11×8 | 11×6 | 11×7 | 11×9 | 11×11 | 11×12 |
| 12 | 12×10 | 12×2 | 12×5 | 12×3 | 12×4 | 12×8 | 12×6 | 12×7 | 12×9 | 12×11 | 12×12 |

Reading



AUTUMN TERM 2022 READING

Each week in the autumn term, you will need to make sure that you have read for at least an hour at home and recorded your reading on the Book Tracker:

| <u>Wk</u> | <u>Book title and Author</u> (☺ CAPITAL LETTERS) | <u>Pages I have read</u> <u>this week</u> |
|-----------|---|--|
| 1 | The Boy at the Back of the Class <u>Onjali Rauf</u> | 123 - 186 |

For most of our children reading chapter books, teachers will be checking that they are reading between 60-100 pages (minimum) a week and reading a new book every 2-3 weeks. Of course, children may take more or less time to read a book, depending on its length and complexity.

Year 3 & 4 Reading as a Writer

- Charlie and the Chocolate Factory – Roald Dahl
- The Butterfly Lion – Michael Morpurgo
- Cliffhanger – Jacqueline Wilson
- Krindlekrax – Philip Ridley
- Max and Millions – Ross Montgomery
- Operation Gadgetman – Malorie Blackman
- How to Train your Dragon – Cressida Cowell
- The Accidental Prime Minister – Tom McLaughlin
- My Brother is a Superhero – David Solomons
- A Series of Unfortunate Events – Lemony Snicket
- The 13-Storey Tree House – Andy Griffiths
- Stuart Little – EB White
- The Last Bear – Hannah Gold
- The Unlikely Adventures of Mabel Jones – Will Mabbit
- Small Change for Stuart – Lissa Evans
- Goblins – Philip Reeve
- The Super Miraculous Journey of Freddie Yates – Jenny Pear
- The Train to Impossible Places – PG Bell
- The Accidental Diary of BUG – Jen Carney
- Spy Dog – Andy Cope
- The World According to Humphry – Betty G Birney
- The Giggler Treatment – Roddy Doyle
- Billionaire Boy – David Walliams
- Planet Omar: Accidental Trouble Magnet – Zanib Mian
- Mia Hayhem is a Superhero – Kara West
- The Beast and the Bethany – Jack Meggitt-Philips
- Cookie – Konnie Huq
- I Swapped my Brother on the Internet – Jo Simmons
- Dave Pigeon – Swapna Haddow
- The Perfect Parent Project – Stewart Foster

Years 3 and 4 Non-fiction Book List

Award-winning Non-fiction

- [A Day in the Life of a Poo, a Gnu and You](#) by Mike Barfield
- [Do You Love Bugs?](#) by Matt Robertson
- [The Epic Book of Epicness](#) by Adam Frost
- [The Silly Book of Side-Splitting Stuff](#) by Andy Seed and Scott Garrett

Amazing Animals

- [Atlas of Animal Adventures](#) by Rachel Williams and Emily Hawkins
- [The Illustrated Encyclopaedia of Ugly Animals](#) by Sami Bayly
- [Nose Knows: Wild Ways Animals Smell the World](#) by Emmanuelle Figueras and Claire De Gastold

Beautiful Biographies

- [How to be Extraordinary](#) by Rashmi Sirdeshpande
- [Young Heroes](#) by Lulu Bridgeport
- [Fantastically Great Women Who Changed the World](#) by Kate Pankhurst
- [Greta Thunberg \(Little People, Big Dreams\)](#) by Maria Isabel Sanchez Vegara and Anke Weckmann
- [Little Leaders: Bold Women in Black History](#) by Vashti Harrison

Books about the Body

- [The Usbourne Book of the Brain and How it Works](#) by Betina Ip
- [Kay's Anatomy: A Complete \(and Completely Disgusting\) Guide to the Human Body](#) by Adam Kay and Henry Paker
- [The Lists for Curious Kids: Human Body](#) by Rachel Delahaye

Facts and Figures

- [The Element in the Room: Investigating the Atomic Ingredients that Make Up Your Home](#) by Mike Barfield and Lauren Humphrey
- [The Everyday Journeys of Ordinary Things: From Phones for Food and From Paper to Poo... the Ways the World Works](#) by Libby Deutsch and Verpuli Kerttula
- [How Many Spots has a Cheetah Got? Number Facts from Around the World](#) by Steve Martin and Amber Davenport

Nutty Non-fiction

- [Funny Bums, Freaky Beaks and Other Incredible Creature Features](#) by Alex Morss, Sean Taylor and Sarah Edmonds
- [Pooh \(A Natural History of the Unmentionable\)](#) by Nicola Davies
- [What's Weird on Earth: Our Strange World as You've Never Seen it Before!](#) By DK
- [You're Called What?](#) by Kes Gray and Nikki Dyson

As well as these books, your child might be interested in subscribing to one of the following non-fiction magazines: **National Geographic Kids** (8-12), **First News** or **Aquila** (8-12).

Spelling Book

✓ AT THE FRONT

- Spelling patterns for your child's spelling group.
- Pre-learning and post learning to identify spelling errors
- In-class spelling tasks/practice
- Personal spelling practice – the spelling is the focus!

✓ AT THE BACK

- My Tricky Spellings – bespoke word list of common misspelt words identified by the teacher – please check copying- thank you!
- Year 4 tricky words



Spelling Group

- We are continuing our spelling focus by consolidating phonic knowledge based in gaps identified post Covid.
- Praised by OFSTED for our phonics recovery.
- We will reassess each child using the No Nonsense Phonics programme which will inform spelling lists/ activities given in their spelling book.
- Children who are ready to access the Year 3 spelling curriculum with the intention of moving on to the Year 4 curriculum after Christmas.
- We aim to finish the year with all children accessing the LKS2 spelling curriculum.

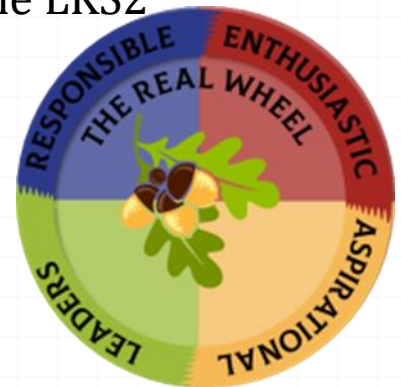

Trips

o **Castleton**



This has been booked for the week beginning 15th January.

First half: 15th – 16th January

Second half: 17th – 18th January

Parents' briefing – 4th December

Possibilities

- Survey in local community – Autumn 1
- Bolton Octagon Christmas Panto – 20th December
- Whitworth Art Gallery – Summer 2
- *Any additional trips will be advised in good time*

Routines

- o **Monday:** Outdoor PE. The children will come in to school in sports clothes – shorts and family t-shirt. Remember, we are moving into winter so jogging bottoms and jumpers/hoodies will be needed.
 - o Reading diaries, spelling books and TTRS checked. Those who have not completed their reading record will read with AHTs for 15 minutes on Monday lunch time. Uncompleted TTRS homework will be done on Wednesday lunch time.
 - o **Wednesday:** Indoor games. Again, please send the children to school on this day in their PE kit.
1. **Reading book** and **spelling book** to be taken home every night and brought back the next day.
 2. Children have the opportunity to change their reading books regularly from their class library/book band library but are welcome to bring their own book from home too.



Other Reminders

School website

Twitter - @HurstheadJnrs

Hursthead Headlines

